

## FLOAT TABLE • Ergonomic Tools

### DESCRIPTION

#### Float Table

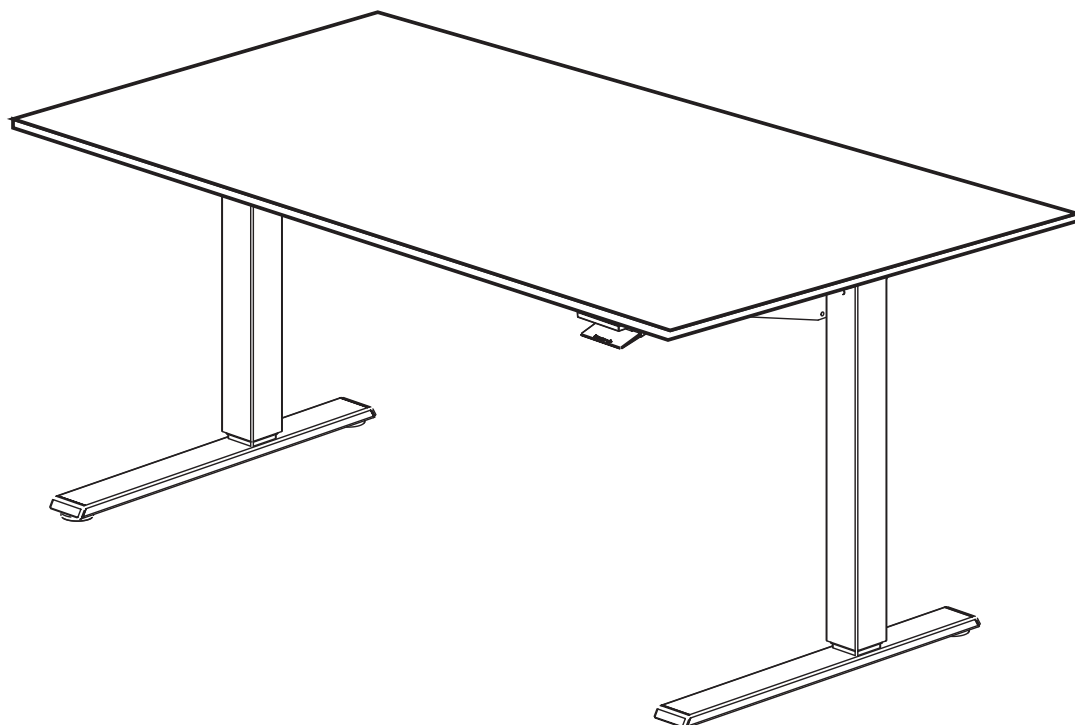

- Enables easy, one-hand counterbalance weight adjustment, and near-effortless height adjustment for ergonomic sit-stand usage through a unique counterbalance mechanism and weight indicator.
- Neatly “floats” into position when its release is engaged—for weightless adjustment without force.
- Provides an impressive 20" of near-effortless height adjustment (from 28" to 48").
- Supports up to 130 lbs.
- Sturdy base constructed of recyclable steel and aluminum; meets BIFMA load and capacity requirements.
- Wood tops: 1-1/8" cherry hardwood with wood veneer.
- Laminate tops: 1-1/8" engineered wood substrate with durable high-pressure laminate.
- Removable tension adjuster included.

#### NOTE:

Refer to attached "How to Build Your Float Table Product Code" for options & cost.

See "OFG Finish Options Card" for Top & Trim Finish color/material selections.

Pricing shown is discounted to match GSA. Additional discounting available for large quantities. Contact your sales rep for more information.

Product dimensions shown in approximate inches.

## How to Build Your LAMINATE TOP Float Table Product Code

|                      | PRODUCT NUMBER       | MAX. WEIGHT LOAD (LBS.) |                      | SHIP WGHT. | FOB. DEST. | BASE COLOR   | SELECT LAMINATE TOP FINISH OPTIONS   |  |  |
|----------------------|----------------------|-------------------------|----------------------|------------|------------|--|--|--|--|
|                      | LAMINATE TOP (W x D) | NORMAL CYLINDER         | HEAVY DUTY CYLINDER* | (LBS)      |            |  | TOP COLOR/FINISH   | TOP TRIM COLOR   |  |
| <b>LAMINATE TOPS</b> | FL2448 = 23"W x 47"D | 97                      | 127                  | 104        | \$1,047    | BR = Black Base<br>SR = Silver Base<br>WR = White Base | <b>SOLID</b><br>AA = Sail White<br>FF = Pumice<br>BM = Oyster Gray<br>BH = Indian Smoke<br>AC = Barcelona<br>BI = Mid Value<br>FG = Neutral White<br>DC = Grey<br>FH = Graystone<br>FK = Folkstone<br>DD = Dove Grey<br>FM = Mouse<br>FP = Brite White<br>AG = Black<br>FN = Graphite<br><br><b>WOOD</b><br>BL = Natural Maple<br>CA = Amber Cherry<br>CB = Colombian Walnut<br>CC = Kensington Maple<br>CD = Biltmore Cherry<br>CE = Empire Mahogany<br>CF = Monticello Maple<br>CG = Shaker Cherry<br>CK = Yarrow<br>CM = Studio Teak<br>CN = Silver Alchemy<br><br><b>NOTE:</b><br>CM - Studio Teak<br>CK - Yarrow<br>have textured surfaces. | <b>PATTERN</b><br>FA = Sail White Oxide<br>FB = Antique White<br>BP = Flax Gauze<br>AU = SandStone<br>AP = Earthen Terra<br>BN = Shoji Screen<br>CP = White Tigris<br>AO = Tundra Terra<br>CR = Pearl Soapstone<br>FC = Natural Canvas<br>FD = Jute Gauze<br>FE = Earth Wash<br>CS = Desert Zephyr<br>CT = Grey Tigris<br>CU = Canyon Zephyr<br>CV = Misted Zephyr<br>CX = Twilight Zephyr<br>CY = Oiled Soapstone<br>CZ = Gilded Mesh<br>DA = Pewter Mesh<br>DB = Steel Mesh<br><br><b>ACCENT</b><br>DE = Satin Stainless<br>DF = Pewter Brush<br>FR = Dogbone White<br>FS = Dogbone Storm<br>FT = Geo Fossil<br>FV = Geo White<br>FX = Tangle Smoke<br>FZ = Beluga<br>GA = Beluga Beige<br>GB = Fossil Weft<br>GC = Seed Weft<br>GD = Café Weft<br>GF = Earthen Warp | *AG = Black<br>*FP = Brite White<br>*DG = Grey<br>*LG = Light Tone<br>*SA = Sand<br>*WG = Warm Grey<br>CD = Biltmore Cherry<br>CB = Colombian Walnut<br>CE = Empire Mahogany<br>CC = Kensington Maple<br>CF = Monticello Maple<br>CG = Shaker Cherry<br>CN = Silver Alchemy<br>CM = Studio Teak<br>CK = Yarrow<br><br>* finishes that match Systems Colors |
|                      | FL2454 = 23"W x 53"D | 93                      | 123                  | 108        | \$1,077    |  |  |  |  |
|                      | FL2460 = 23"W x 59"D | 89                      | 119                  | 114        | \$1,098    |  |  |  |  |
|                      | FL2466 = 23"W x 65"D | 82                      | 112                  | 121        | \$1,122    |  |  |  |  |
|                      | FL2472 = 23"W x 71"D | 77                      | 107                  | 126        | \$1,147    |  |  |  |  |
|                      | FL3048 = 29"W x 47"D | 86                      | 116                  | 121        | \$1,062    |  |  |  |  |
|                      | FL3054 = 29"W x 53"D | 82                      | 112                  | 125        | \$1,086    |  |  |  |  |
|                      | FL3060 = 29"W x 59"D | 76                      | 106                  | 134        | \$1,110    |  |  |  |  |
|                      | FL3066 = 29"W x 65"D | 70                      | 100                  | 140        | \$1,134    |  |  |  |  |
|                      | FL3072 = 29"W x 71"D | 63                      | 93                   | 147        | \$1,159    |  |  |  |  |

\* Heavy duty cylinder sold separately. See Float Table Accessories on page 5.

 Heavy duty cylinder (sold separately)

**TO ORDER:**

For example, to order a Float Table with a 29"W x 47"D Laminate Top (FL3048), on a Black Metal Base (BR), with Black Laminate Top Color (AG), and Black Laminate Top Trim Color (AG), specify:

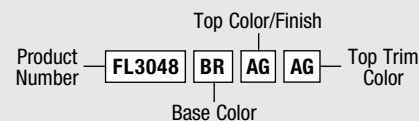

## How to Build Your WOOD TOP Float Table Product Code

|                  | PRODUCT NUMBER       | MAX. WEIGHT LOAD (LBS.) |                      | SHIP WGHT. | FOB. DEST. | BASE COLOR   | SELECT WOOD TOP FINISH OPTIONS              |  |
|------------------|----------------------|-------------------------|----------------------|------------|------------|--|---|--|
|                  | WOOD TOP (W x D)     | NORMAL CYLINDER         | HEAVY DUTY CYLINDER* | (LBS)      |            |  | TOP COLOR                                   | TOP TRIM STYLE   |
| <b>WOOD TOPS</b> | FW2448 = 23"W x 47"D | 100                     | 130                  | 101        | \$1,109    | BR = Black Base<br>SR = Silver Base<br>WR = White Base | CH = Cherry<br>MH = Mahogany<br>WN = Walnut | B = Baritone<br>C = Concerto<br>S = Symphony<br>F = Flat<br><br>See appropriate Casegoods catalog for description of edge style. |
|                  | FW2454 = 23"W x 53"D | 96                      | 126                  | 105        | \$1,134    |  |   |  |
|                  | FW2460 = 23"W x 59"D | 92                      | 122                  | 111        | \$1,166    |  |   |  |
|                  | FW2466 = 23"W x 65"D | 88                      | 118                  | 115        | \$1,198    |  |   |  |
|                  | FW2472 = 23"W x 71"D | 84                      | 114                  | 119        | \$1,220    |  |   |  |
|                  | FW3048 = 29"W x 47"D | 92                      | 122                  | 115        | \$1,139    |  |   |  |
|                  | FW3054 = 29"W x 53"D | 87                      | 117                  | 120        | \$1,171    |  |   |  |
|                  | FW3060 = 29"W x 59"D | 82                      | 112                  | 128        | \$1,203    |  |   |  |
|                  | FW3066 = 29"W x 65"D | 77                      | 107                  | 133        | \$1,235    |  |   |  |
|                  | FW3068 = 29"W x 67"D | 76                      | 106                  | 134        | \$1,267    |  |   |  |
|                  | FW3072 = 29"W x 71"D | 72                      | 102                  | 138        | \$1,299    |  |   |  |

\* Heavy duty cylinder sold separately. See Float Table Accessories on page 5.

 Heavy duty cylinder (sold separately)

**TO ORDER:**

For example, to order a Float Table with a 29"W x 47"D Wood Top (FL3048), on a Silver Metal Base (SR), with Mahogany Top Color (MH), and Symphonie Top Trim Style (S), specify:

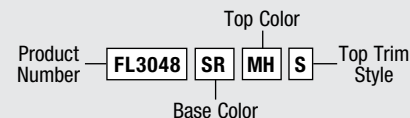

**FLOAT TABLE • Accessories • Ergonomic Tools**

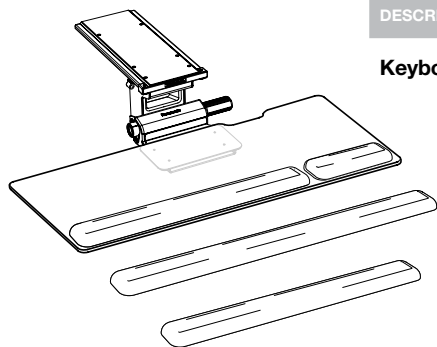

| DESCRIPTION     | PRODUCT NUMBER  | MECHANISM COLOR | WIDTH X DEPTH | PALM SUPPORT                          | TRACK DEPTH | SHIP WGT | FOB DEST |
|-----------------|-----------------|-----------------|---------------|---------------------------------------|-------------|----------|----------|
| <b>Keyboard</b> | EK6FB259F125    | Black           | 25" x 9"      | 19" Foam with Synthetic Leather Cover | 12.5"       | 8 lbs    | \$114.75 |
|                 | EK6FW259F125    | White           | 25" x 9"      | 19" Foam with Synthetic Leather Cover | 12.5"       | 8 lbs    | \$114.75 |
|                 | EK6FB259G125    | Black           | 25" x 9"      | 19" Gel with Synthetic Leather Cover  | 12.5"       | 8 lbs    | \$114.75 |
|                 | EK6FW259G125    | White           | 25" x 9"      | 19" Gel with Synthetic Leather Cover  | 12.5"       | 8 lbs    | \$114.75 |
|                 | EK6FB259S125    | Black           | 25" x 9"      | 19" Slim                              | 12.5"       | 8 lbs    | \$114.75 |
|                 | EK6FW259S125    | White           | 25" x 9"      | 19" Slim                              | 12.5"       | 8 lbs    | \$117.75 |
|                 | EK6FB500F2714   | Black           | 27" x 10.625" | 27" Foam with Synthetic Leather Cover | 14"         | 8 lbs    | \$114.75 |
|                 | EK6FB500G2714   | Black           | 27" x 10.625" | 27" Gel with Synthetic Leather Cover  | 14"         | 8 lbs    | \$127.58 |
|                 | EK6FB500SMP2714 | Black           | 27" x 10.625" | 19" & 7" Slim                         | 14"         | 8 lbs    | \$127.58 |
|                 | EK6FW500SMP2714 | White           | 27" x 10.625" | 19" & 7" Slim                         | 14"         | 8 lbs    | \$127.58 |
|                 | EK6FB550F2514   | Black           | 25" x 10.625" | 25" Foam with Synthetic Leather Cover | 14"         | 8 lbs    | \$117.75 |
|                 | EK6FB550G2514   | Black           | 25" x 10.625" | 25" Gel with Synthetic Leather Cover  | 14"         | 8 lbs    | \$117.75 |
|                 | EK6FB550SMP2514 | Black           | 25" x 10.625" | 19" & 5" Slim                         | 14"         | 8 lbs    | \$127.58 |
|                 | EK6FW550SMP2514 | White           | 25" x 10.625" | 19" & 5" Slim                         | 14"         | 8 lbs    | \$127.58 |

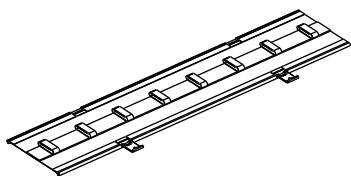

| DESCRIPTION                      | PRODUCT NUMBER | BASKET/TRIM COLOR | WIDTH X DEPTH | LENGTH | SHIP WGT | FOB DEST |
|----------------------------------|----------------|-------------------|---------------|--------|----------|----------|
| <b>NeatTech Cable Management</b> | WCMNTSGG       | Gray/Gray         | 4" x 4.5"     | 38"    | 2 lbs    | \$74.40  |
|                                  | WCMNTSGR       | Gray/Red          | 4" x 4.5"     | 38"    | 2 lbs    | \$74.40  |
|                                  | WCMNTLGG       | Gray/Gray         | 4" x 4.5"     | 48"    | 3 lbs    | \$79.20  |
|                                  | WCMNTLGR       | Gray/Red          | 4" x 4.5"     | 48"    | 3 lbs    | \$79.20  |

Pricing shown is discounted to match GSA. Additional discounting available for large quantities. Contact your sales rep for more information.  
Product dimensions shown in approximate inches.

## FLOAT TABLE • Accessories • Ergonomic Tools

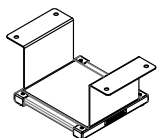

| DESCRIPTION  | PART NUMBER | COLOR  | SHIP WEIGHT | DEST PRICE |
|--|-------------|--------|-------------|------------|
| <b>CPU Bracket</b><br>*Required mounting bracket for CPU Holders listed below. | FCBB        | Black  | 1 lbs.      | \$28.80    |
|  | FCBS        | Silver | 1 lbs.      | \$28.80    |
|  | FCBW        | White  | 1 lbs.      | \$28.80    |

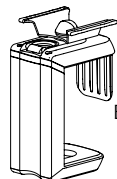

EPCU200/W

| DESCRIPTION                                | PART NUMBER | COLOR | CPU SIZE        | MAX. WEIGHT | SHIP WEIGHT | DEST PRICE |
|--|-------------|-------|-----------------|-------------|-------------|------------|
| <b>CPU Holder</b><br>*CPU Bracket required | EPCU200     | Black | 1 to 5"W x 12"H | 15 lbs.     | 10 lbs.     | \$51.20    |
|  | EPCU200W    | White | 1 to 5"W x 12"H | 15 lbs.     | 10 lbs.     | \$51.20    |

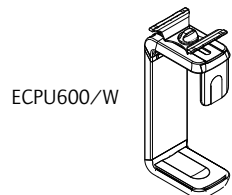

EPCU600/W

|  |          |       |                          |         |         |         |
|--|----------|-------|--------------------------|---------|---------|---------|
| <b>CPU Holder</b><br>*CPU Bracket required | EPCU600  | Black | 3.5 to 9"W x 12" to 20"H | 50 lbs. | 12 lbs. | \$53.76 |
|  | EPCU600W | White | 3.5 to 9"W x 12" to 20"H | 50 lbs. | 12 lbs. | \$53.76 |

| DESCRIPTION                    | PART NUMBER | SHIP WEIGHT | DEST PRICE |
|--------------------------------|-------------|-------------|------------|
| <b>Heavy Duty Cylinder Kit</b> | FHDCYL      | 5 lbs.      | \$71.75    |

- Under-the-desk track provides easy access or convenient stowing.
- One-touch 360° swivel motion provides effortless access to cables, ports and drives.
- Helps prevent awkward postures that could lead to injury.
- Promotes longer CPU life by allowing CPUs to stay cool and vent freely.
- Elevates CPUs off the floor where dust build-up and other hazards can damage valuable computer equipment.

Pricing shown is discounted to match GSA. Additional discounting available for large quantities. Contact your sales rep for more information.

Product dimensions shown in approximate inches.

## Terms and Conditions

### The Customer Service Center

Contact the UNICOR/OFG Customer Service Center for any questions or assistance regarding the information in this price list. Our business hours are 7:30 AM to 5:45 PM (EST), Monday through Friday (excluding Federal holidays). Our phone number is (800) 827-3168.

### Order Acknowledgment

UNICOR/OFG acknowledges every order. Orders are accepted, filled, and invoiced based on the information in this written order-confirmation. UNICOR/OFG contracts with a third party for services and installation in support of its product(s) on the customer's behalf. Services and installation represent a separate portion of the customer's agreement. Payment for furniture is due and payable upon delivery of product. Payment for services and installation is due and payable upon completion of the support services. Should you note any discrepancy, please advise immediately.

Your order acknowledgment indicates a due date when your products will arrive. In the event your products are manufactured earlier than scheduled, we will ship them upon completion, providing that your purchase order states "Early Shipments Authorized."

### Order Modifications

Modification to your purchase order will be accepted up to 8 weeks prior to the due date indicated on your order acknowledgment. However, if the revision results in a change in product availability, a new due date may be set by UNICOR/OFG. Such due date adjustment may be for your full purchase order, whether or not the specifications of all line-items on it are modified. All purchase order modifications are acknowledged in writing, including the annotation of any adjusted due date(s).

Changes requested after we obtain materials for your order may be subject to an upcharge. Confirmation of your order modification will note any such additional charge(s).

### Standard Lead Time

Typical lead time for Concerto product delivery is 45 days after receipt of your order.

### Product Delivery and Pricing

We take both FOB Origin and FOB Destination orders. All products are shipped via surface transportation.

On FOB Origin orders, title/product-responsibility passes to the customer at the time of shipment. You may arrange your own transportation on FOB Origin orders, coordinating with FPI accordingly. Otherwise, your order will be shipped by common carrier at your expense.

On FOB Destination orders, title/ product-responsibility passes to the customer upon delivery to the dock of the designated point-of-delivery. Freight charges are included in the product prices listed in the FOB Destination column of this price list.

Contact your local OFG Sales Representative for destination prices where none are given. Such destination pricing for delivery outside The continental U.S. must be negotiated based on the freight rates at time of shipment.

Services, such as space planning/design, storage, inside-delivery and installation is not addressed as part of this price list. Contact your local OFG Sales Representative for such service-fee quotations. To locate your local OFG sales Representative, go on line to [unicor.gov/ofgsales](http://unicor.gov/ofgsales)

### Pricing & Volume Discounts

Contact your local OFG Sales Representative for any special agency pricing or volume discounts. To locate your local OFG Sales Representative go on line to [unicor.gov/ofgsales](http://unicor.gov/ofgsales)

### Special Packaging

Standard packaging varies per individual product. UNICOR/OFG will accommodate your special packaging requests, however, an upcharge may apply. Contact the Customer Service Center for more information.

### Shipment Claims

UNICOR/OFG products are packed to comply with carrier requirements. All shipments should be inspected by the consignee before acceptance.

The delivering carrier should be requested to record any damage or shortage of items shipped. If any shortages are discovered, please also notify UNICOR/OFG Customer Service Center immediately.

Shipping damage and shortage claims must be filed with the carrier within 15 days of delivery. This applies to both FOB Destination and FOB Origin shipments. Carrier liability ends after 15 days for shipping damages or shortages.

### Concealed Damage Claims

Claims for concealed damages must be filed with the carrier within 15 days after the delivery of goods. This applies to both FOB Destination and FOB Origin shipments. Carrier liability ends after 15 days for concealed damages.

Neither UNICOR/OFG nor the carrier will be responsible for concealed damages if shipments are left unopened and/or claims are not filed within 15 days.

### Customer-Delayed Deliveries

Please notify the Customer Service Center at least 2 weeks prior to the confirmed due date when you cannot receive delivery of goods by that scheduled date. We will delay the delivery at your request. However, after 30 days of such delay, you will be invoiced for the subject products whether or not delivery is extended beyond this first 30 days.

## OFG Warranty/Life Expectancy

UNICOR/OFG may allow up to 2 weeks for shipping. Therefore, if you do not request delayed delivery at least 2 weeks prior to the confirmed due date for arrival of your shipment, we may incur additional handling costs.

UNICOR/OFG will bill you for such handling costs if you refuse receipt of the goods, or request delayed shipment in less than 2 weeks prior to the due date on your order acknowledgment.

### Product Returns

All product returns must be coordinated in advance with the UNICOR/OFG Customer Service Center. In addition, all freight or express service charges must be prepaid on return shipments.

Product returns may be subject to your being invoiced for additional handling/restocking fees. UNICOR/OFG will determine and notify you of such charges upon receipt and inspection of the returned goods.

### Order Status

Call the Customer Service Center to obtain status of your order during order processing or the production and shipment/delivery of goods. We will give you the status based on your purchase order number and/or the UNICOR/OFG work order number on your order acknowledgment.

You may also access your order status by clicking on the customer service icon on our web site at [www.unicor.gov](http://www.unicor.gov)

### Invoice Payment

Payments from government agencies should be addressed to:

UNICOR - FPI  
P.O. Box 371736  
Pittsburgh PA 15252-7736

Payments from private sector parties should be addressed to:

UNICOR - LEX  
Accounts Receivable  
P.O. Box 11670  
Lexington KY 40583-3640

All general billing or specific invoice questions should be directed to the UNICOR/OFG Customer Service Center.

### Product Warranty

UNICOR/OFG guarantees all furniture products will be free from defects in materials and workmanship.

### Product Finishes

Photographic finish samples for our ergonomic products are shown in the Ergonomic Tools catalog. We have taken great care to accurately reproduce these finishes. However, there may be variations between the photographic and actual finishes.

OFG guarantees all furniture to be free from defects in materials and workmanship. This guarantee applies to the original purchaser of the item and is in effect upon receipt of the item. If at any time an item we have provided does not perform to industry standards we will replace or repair it.

While we stand behind our commitment to provide the highest quality standards, there is a life expectancy of products based upon normal use defined as being 40 hours per week by individuals weighing 250 lbs. or less (unless otherwise indicated) and not subjected to abuse or misuse.

Under normal use conditions products have the following warranty:

### Ergonomic Accessories

- **High wear components** such as gas cylinders are warranted for 12 years after date of shipment to original owner.
- **Element Light, including Light Source** have a 10 years, 24/7 warranty.
- **Wall Mounts** are warranted for 5 years.
- **All other Healthcare Products** not detailed in this price guide have various warranties. Consult your representative for details.

## How To Order

### By Internet

We're ready to take your electronic order. See us at:

[www.unicor.gov/ofg](http://www.unicor.gov/ofg)

### By Phone

Use your government credit card and call UNICOR toll free at:

**(800) 827-3168**

### By Fax

Fax your purchase order 24 hours a day to:

**(859) 254-9390 Standard Orders**

**(859) 254-9048 Credit Cards**

### By Mail

Send your purchase order to:

**UNICOR  
Customer Service Center  
P.O. Box 13640  
Lexington, KY 40577-1670**

### Customer Service

For information about products, prices or to request catalogs, call UNICOR Customer Service at (800) 827-3168 from 7:30 a.m. to 6:00 p.m. EST or leave a message at other times. To locate your local OFG Sales Representative, go to [unicor.gov/ofgsales](http://unicor.gov/ofgsales)



## Credit Card Order Form

FAX orders to (859) 254-9048 or call (800) 827-3168. Order online at [www.unicor.gov/ofg](http://www.unicor.gov/ofg).

SHIPPING ADDRESS (NO POST OFFICE BOXES PLEASE)

NAME \_\_\_\_\_

TITLE \_\_\_\_\_

AGENCY \_\_\_\_\_

STREET \_\_\_\_\_

CITY \_\_\_\_\_ STATE \_\_\_\_\_ ZIP \_\_\_\_\_

TELEPHONE (     ) \_\_\_\_\_ FAX NUMBER (     ) \_\_\_\_\_

FAX NUMBER MUST BE INCLUDED

E-MAIL \_\_\_\_\_

CREDIT CARD # \_\_\_\_\_ EXPIRATION DATE \_\_\_\_\_

SIGNATURE \_\_\_\_\_ DATE \_\_\_\_\_

*Please be sure that all information is complete to avoid delaying your order.*

| PRODUCT NUMBER   | DESCRIPTION | COLOR | QUANTITY | UNIT PRICE        | TOTAL |
|--|-------------|-------|----------|-------------------|-------|
|  |             |       |          |                   |       |
|  |             |       |          |                   |       |
|  |             |       |          |                   |       |
|  |             |       |          |                   |       |
|  |             |       |          |                   |       |
|  |             |       |          |                   |       |
|  |             |       |          |                   |       |
|  |             |       |          |                   |       |
|  |             |       |          |                   |       |
|  |             |       |          |                   |       |
|  |             |       |          |                   |       |
|  |             |       |          |                   |       |
|  |             |       |          |                   |       |
|  |             |       |          |                   |       |
|  |             |       |          |                   |       |
|  |             |       |          |                   |       |
|  |             |       |          |                   |       |
| Note: For shipments outside the contiguous U.S.,<br>freight will be based upon rates at the time of delivery.<br><br>Thank you for your order. |             |       |          | Subtotal          |       |
|  |             |       |          | Overseas Shipping |       |
|  |             |       |          | <b>TOTAL</b>      |       |